

A Unique 5 detainer locking mechanism with hook bolt for securing sliding doors

Features

- Brass hook bolt with anti-padsaw steel roller
- Brass stud to prevent door being lifted
- Double sided keylock
- 5 detainer mechanism offering thousands of key combinations
- Built in protection against picking, drilling, force and torque attack
- Bolt through fixing facility
- Steel key
- Optional micro-switches for alarm system integration
- Can be suited as part of a master keyed system with any other CLCS detainer mortice lock

ANTI-PADSAW HOOK BOLT



STUD PREVENTS LIFTING



STEEL KEY



3M51 - DETAINER MORTICE HOOK BOLT LOCK

DIMENSIONS

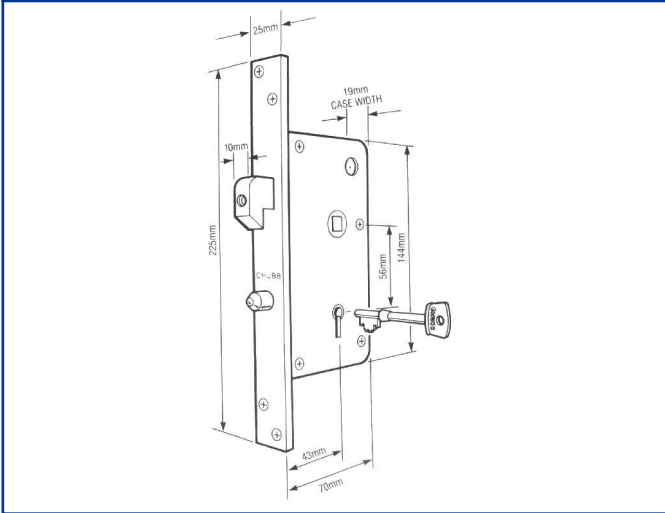

DURABILITY TESTING

Key Operations	60,000
Door Slams	300,000
Salt Spray	30 hours

ORDERING AND INSTALLATION

This lock should not be fitted to a wooded door less that 44mm thick. When fitting to steel doors and grille gates the lock must be housed within the special outer steel box which is welded to the gates. For steel faced doors the outer steel box can only be fitted during the door

manufacture stage and therefore must be ordered well in advance. This literature is designed as a guide to the extensive range of CLCS products. Please contact our technical department before ordering to ensure you have the correct specification for your application.



UK Telephone
Int Telephone
Email
Website

Chubb Locks Custodial Services Ltd
Well lane, Wolverhampton, WV11 1TB, United Kingdom
01902 867730
00 44 1902 867730
sales@clcsLtd.co.uk
www.clcsLtd.co.uk

