

Heavy duty surface/flush mounted cell lock with automatic deadlocking

Features

- Heavy duty steel body
- Anti-padsaw, steel deadbolt with 32mm throw
- Steel deadbolt and brass stud release bolt for automatic deadlocking
- Self contained inner locking unit- replaceable
- Used by UK prison authorities
- Circular indicator showing lock status
- Special device to prevent jamming of lock with foreign objects
- Escutcheon provides positive key location
- Key manufactured from hardened steel
- Integral key bit and stem (extruded section)

LOCK STATUS INDICATOR



ANTI-PADSAW BOLT

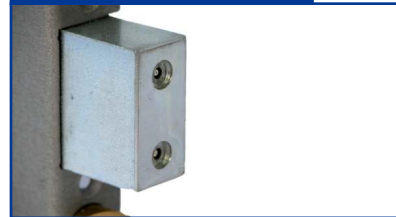

BRASS STUD RELEASE



4L56/4L55 - CELL LOCK WITH AUTOMATIC DEADLOCKING

DIMENSIONS

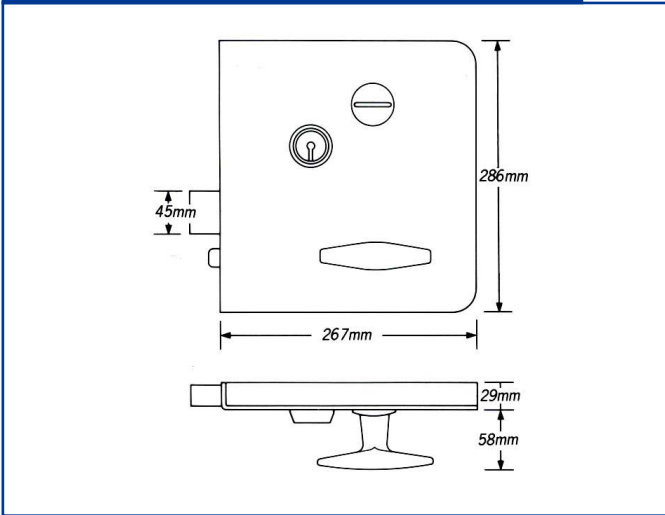

DURABILITY TESTING

Key Operations	100,000
Handle Operations	100,000
Door Slams	100,000
Saw Attack	12 hours

ORDERING AND INSTALLATION

4L56 - Surface Mounted 4L55 - Flush Mounted

The following information is required when ordering -a) Door construction and thickness b) Method of fitting, i.e. back plate or front mounting plate c) Key suiting requirements, i.e. to differ, pass or master keyed d) Hand and opening of lock.

This literature is designed as a guide to the extensive range of CLCS products. Please contact our sales department before ordering to ensure you have the correct specification for your application.



UK Telephone
Int Telephone
Email
Website

Chubb Locks Custodial Services Ltd
Well lane, Wolverhampton, WV11 1TB, United Kingdom
01902 867730
00 44 1902 867730
sales@clcsLtd.co.uk
www.clcsLtd.co.uk

